

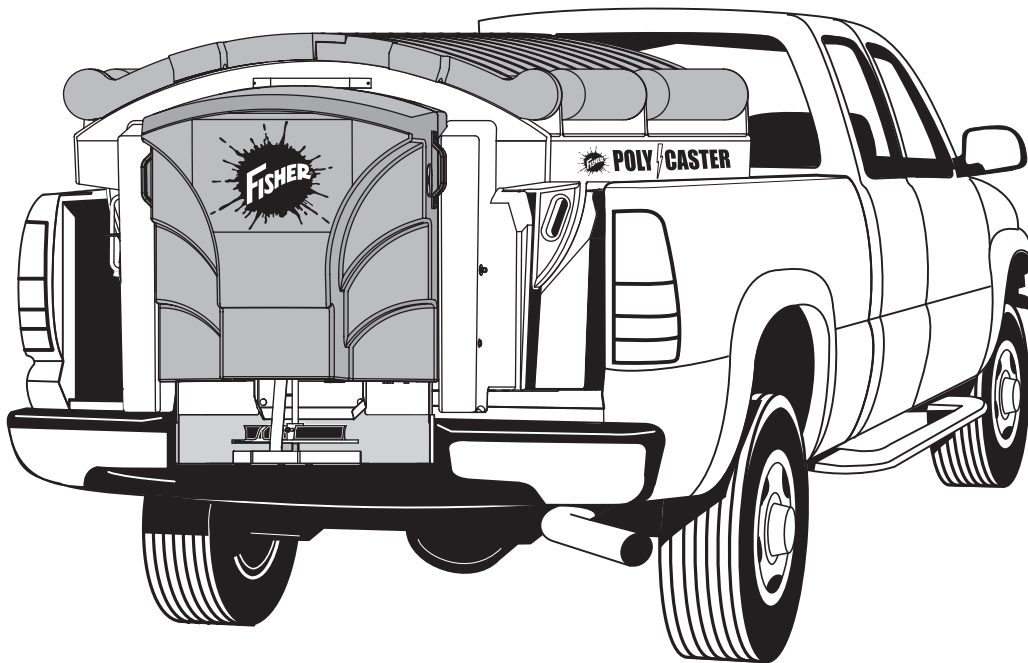

POLY-CASTER™ Hopper Spreader

#78001-1, 78004-1, 78007-1

Owner's Manual



⚠ CAUTION

Read this manual before installing or
operating the spreader.

This manual is for FISHER® POLY-CASTER Hopper Spreaders with serial numbers
beginning with 160905 and higher.

TABLE OF CONTENTS

PREFACE	4	Controlling Material Application	14
Owner's Information.....	4	BLAST/Maximum Application.....	14
SAFETY INFORMATION	5	Cab Controls Modes	14
Safety Definitions	5	Standby Mode	14
Warning/Caution Labels	5	Ready Mode	14
Safety Precautions.....	6	ON Mode	14
Personal Safety.....	6	Error Mode	14
Fire and Explosion.....	7	Cab Control Codes (Table).....	15
Cell Phones.....	7	Setup Procedures	17
Ventilation	7	Calibrate Empty Hopper Setting.....	17
Battery Safety	7	Adjust LED Brightness Level.....	17
Noise.....	7	Dump Function.....	18
Vibration.....	7	Accessory Work Light.....	18
Torque Chart.....	7	REMOVING THE SPREADER	19
LOADING	8	MAINTENANCE	20
Material Weights	8	Grease Fittings	20
Load Volume	8	Conveyor Pintle Chain Tension.....	20
Certification.....	8	After Each Use.....	20
Spreader Specifications.....	9	Storage	21
Determining Vehicle Payload.....	9	At the End of Each Season or	
MOUNTING THE SPREADER	11	After Extended Storage.....	21
OPERATING THE SPREADER	13	Recycle	21
Powering the Control	13	ELECTRICAL COMPONENTS	22
Starting and Stopping Spreader	13	TROUBLESHOOTING GUIDE	24

PREFACE

This manual has been prepared to acquaint you with the safety information, operation and maintenance of your new hopper spreader. Please read this manual carefully and follow all recommendations. This will help ensure profitable and trouble-free operation of your hopper spreader. Keep this manual accessible. It is a handy reference in case minor service is required.

When service is necessary, bring your hopper spreader to your distributor. They know your spreader best and are interested in your complete satisfaction.

NOTE: This spreader is designed to spread snow and ice control materials only. Do not use it for purposes other than those specified in this manual.

Register your spreader online at www.fisherplows.com

OWNER'S INFORMATION

Owner's Name: _____

Date Purchased: _____

Outlet Name: _____ Phone: _____

Outlet Address: _____

Vehicle Model: _____ Year: _____

Spreader Type (Model): _____ Serial #: _____

Length: _____ Weight: _____ lb/kg: _____

SAFETY INFORMATION

SAFETY DEFINITIONS

⚠ WARNING

Indicates a potentially hazardous situation that, if not avoided, could result in death or serious personal injury.

⚠ CAUTION

Indicates a potentially hazardous situation that, if not avoided, may result in minor or moderate injury. It may also be used to alert against unsafe practices.

NOTE: Indicates a situation or action that can lead to damage to your spreader and vehicle or other property. Other useful information can also be described.

WARNING/CAUTION LABELS

Please become familiar with the Warning and Caution labels on the spreader.

NOTE: If labels are missing or cannot be read, see your sales outlet.

⚠ CAUTION

Do not lift spreader by this member. Lifting here could cause personal injury and property damage.

67272

⚠ WARNING

9378.00
With chute removed, use dump switches to operate conveyor.

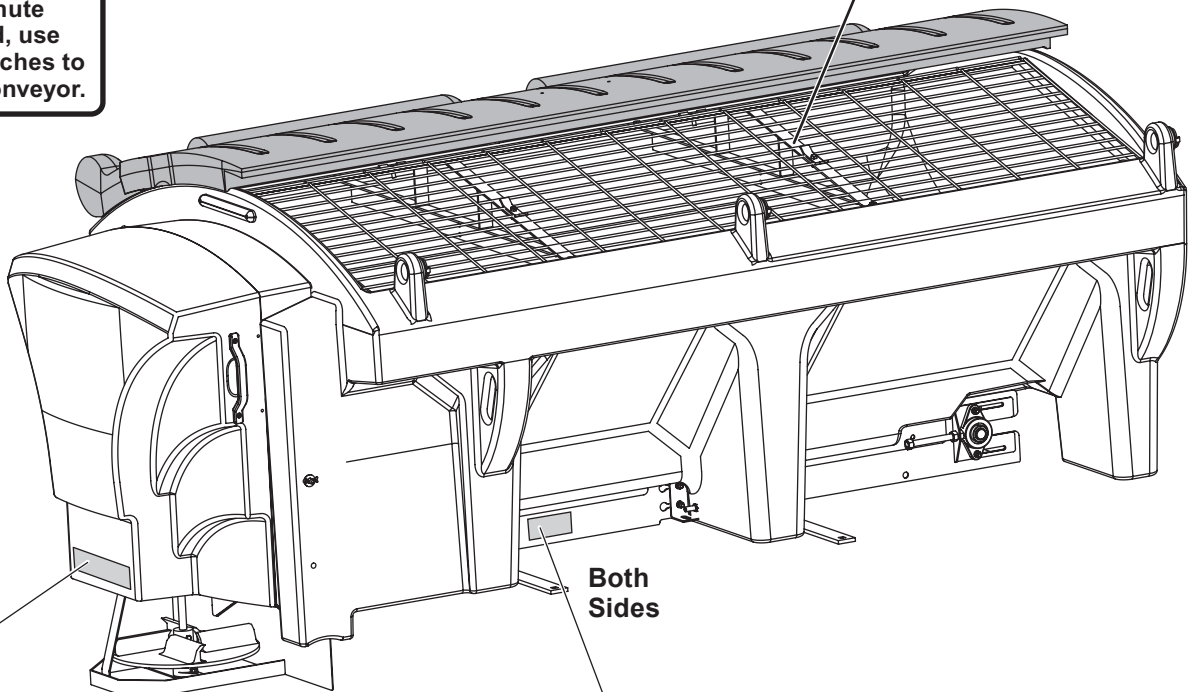

Both Sides

⚠ WARNING



- DO NOT exceed GVWR or GAWR with spreader and load.
- Turn spreader OFF before filling, adjusting or cleaning.
- Bystanders to stay a minimum of 25 feet away from operating spreader.
- DO NOT climb into or ride on spreader.
- Keep hands, feet and clothing away from moving conveyor and spinner.



⚠ CAUTION

- Read Owner's Manual before operating or servicing spreader.
- Empty and clean spreader after every use.

68584

SAFETY INFORMATION

SAFETY PRECAUTIONS

Improper installation and operation could cause personal injury and/or equipment and property damage. Read and understand labels and the Owner's Manual before installing, operating or making adjustments.

WARNING

- Driver to keep bystanders minimum of 25 feet away from operating spreader.
- Before working with the spreader, secure all loose-fitting clothing and unrestrained hair.
- Before operating the spreader, verify all safety guards are in place.
- Before servicing the spreader, wait for conveyor and spinner to stop.
- Do not climb into or ride on spreader.

WARNING



Overloading could result in an accident or damage. Do not exceed GVWR or GAWR ratings as found on the driver-side door cornerpost of the vehicle. See Loading Section to determine maximum volumes of spreading material.

WARNING

Do not install the control for this product in the deployment path of an air bag. Refer to vehicle manufacturer's manual for air bag deployment area(s).

CAUTION

If rear directional, CHMSL light or brake stoplights are obstructed by the spreader, the lights shall be relocated, or auxiliary directional or brake stoplights shall be installed.

CAUTION

During the hopper spreader installation we recommend the addition of an OSHA compliant Backup Alarm. This alarm is required for OSHA governed employers.

CAUTION

- Do not operate a spreader in need of maintenance.
- Before operating the spreader, reassemble any parts or hardware removed for cleaning or adjusting.
- Before operating the spreader, remove materials such as cleaning rags, brushes, and hand tools from the spreader.
- While operating the spreader, use auxiliary warning lights, except when prohibited by law.
- Tighten all fasteners according to the Torque Chart. Refer to Torque Chart for the recommended torque values.

CAUTION

Disconnect electric and/or hydraulic power and tag out if required before servicing or performing maintenance.

CAUTION



DO NOT leave unused material in hopper. Material can freeze or solidify, causing unit to not work properly. Empty and clean after each use.

NOTE: Lubricate grease fittings after each use. Use a good quality multipurpose grease.

PERSONAL SAFETY

- Remove ignition key and put the vehicle in park or in gear to prevent others from starting the vehicle during installation or service.
- Wear only snug-fitting clothing while working on your vehicle or spreader.
- Do not wear jewelry or a necktie, and secure long hair.
- Wear safety goggles to protect your eyes from battery acid, gasoline, dirt and dust.
- Avoid touching hot surfaces such as the engine, radiator, hoses and exhaust pipes.
- Always have a fire extinguisher rated BC handy, for flammable liquids and electrical fires.

SAFETY INFORMATION

FIRE AND EXPLOSION

⚠ WARNING

Gasoline is highly flammable and gasoline vapor is explosive. Never smoke while working on vehicle. Keep all open flames away from gasoline tank and lines. Wipe up any spilled gasoline immediately.

Be careful when using gasoline. Do not use gasoline to clean parts. Store only in approved containers away from sources of heat or flame.

CELL PHONES

A driver's first responsibility is the safe operation of the vehicle. The most important thing you can do to prevent a crash is to avoid distractions and pay attention to the road. Wait until it is safe to operate Mobile Communication Equipment such as cell phones, text messaging devices, pagers or two-way radios.

VENTILATION

⚠ WARNING

Vehicle exhaust contains lethal fumes. Breathing these fumes, even in low concentrations, can cause death. Never operate a vehicle in an enclosed area without venting exhaust to the outside.

BATTERY SAFETY

⚠ CAUTION

Batteries normally produce explosive gases which can cause personal injury. Therefore, do not allow flames, sparks or lit tobacco to come near the battery. When charging or working near a battery, always cover your face and protect your eyes, and also provide ventilation.

- **Batteries contain sulfuric acid which burns skin, eyes and clothing.**
- **Disconnect the battery before removing or replacing any electrical components.**

NOISE

Airborne noise emission during use is below 70 dB(A) for the spreader operator.









VIBRATION

Operating spreader vibration does not exceed 2.5 m/s² to the hand-arm or 0.5 m/s² to the whole body.

TORQUE CHART

⚠ CAUTION

Read instructions before assembling. Fasteners should be finger tight until instructed to tighten according to torque chart. Use standard methods and practices when attaching spreader including proper personal protective safety equipment.

Recommended Fastener Torque Chart					
Inch Fasteners Grade 5 and Grade 8					
Size	Torque (ft-lb)		Size	Torque (ft-lb)	
	 Grade 5	 Grade 8		 Grade 5	 Grade 8
1/4-20	8.4	11.9	9/16-12	109	154
1/4-28	9.7	13.7	9/16-18	121	171
5/16-18	17.4	24.6	5/8-11	150	212
5/16-24	19.2	27.3	5/8-18	170	240
3/8-16	30.8	43.6	3/4-10	269	376
3/8-24	35.0	49.4	3/4-16	297	420
7/16-14	49.4	69.8	7/8-9	429	606
7/16-20	55.2	77.9	7/8-14	474	669
1/2-13	75.3	106.4	1-8	644	909
1/2-20	85.0	120.0	1-12	704	995
Metric Fasteners Class 8.8 and 10.9					
Size	Torque (ft-lb)		Size	Torque (ft-lb)	
	 Class 8.8	 Class 10.9		 Class 8.8	 Class 10.9
M6 x 1.00	7.7	11.1	M20 x 2.50	325	450
M8 x 1.25	19.5	26.9	M22 x 2.50	428	613
M10 x 1.50	38.5	53.3	M24 x 3.00	562	778
M12 x 1.75	67	93	M27 x 3.00	796	1139
M14 x 2.00	107	148	M30 x 3.50	1117	1545
M16 x 2.00	167	231	M33 x 3.50	1468	2101
M18 x 2.50	222	318	M36 x 4.00	1952	2701
These torque values apply to fasteners except those noted in the instructions.					

LOADING

This Manual covers vehicles which have been recommended for carrying the hopper spreader. Please see your local dealer for proper vehicle applications.

⚠ WARNING

Overloading could result in an accident or damage. Do not exceed GVWR or GAWR as found on the driver-side cornerpost of vehicle.

CERTIFICATION

⚠ WARNING

New untitled vehicle installation of a spreader requires National Highway Traffic Safety Administration altered vehicle certification labeling. Installer to verify that struck load of snow or ice control material does not exceed GVWR or GAWR rating label and complies with FMVSS.

MATERIAL WEIGHTS

⚠ CAUTION



Read and adhere to manufacturer's ice-control material package labeling, including Material Safety Data Sheet requirements.

Material	Density (lb per cubic yd)
Fine Salt – Dry	1,350
Coarse Salt – Dry	1,215
Coarse Sand – Dry	2,700
Coarse Sand – Wet	3,240
Cinders	1,080

Load Volume

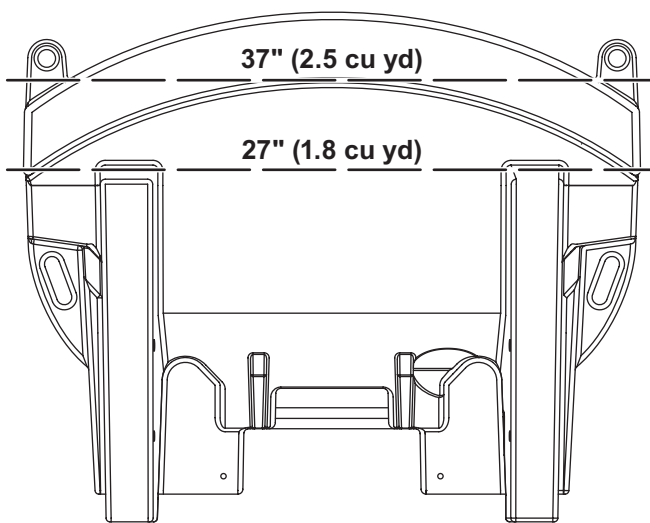

8' Unit

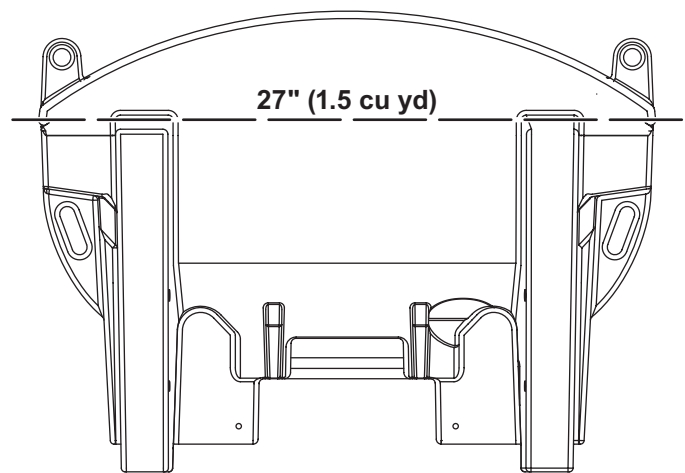

7' Unit

LOADING

SPREADER SPECIFICATIONS

Spreader Description	Overall Length (in)	Empty Weight (lb)	Capacity Struck (cu yd)	Overall Width (in)	Overall Height (in)	Recommended Use
Regular Capacity 7' Hopper Body Double-Wall Poly	108	591	1.5	63	44	3/4–1 ton Pickup Trucks above 8500 lb GVWR
8' Hopper Body w/o Collar Double-Wall Poly	117	660	1.8	63	44	3/4–1 ton Pickup Trucks above 8500 lb GVWR
8' Hopper Body w/ Collar Double-Wall Poly	117	734	2.5	63	51	Dump Body – Flatbed

DETERMINING VEHICLE PAYLOAD

⚠ WARNING

Overloading could result in an accident or damage. Do not exceed GVWR or GAWR ratings as found on the driver-side door cornerpost of the vehicle. See Loading Section to determine maximum volumes of spreading material.

1. Install the hopper spreader and optional equipment according to the instructions.
2. Install or attach any other equipment that will be on the vehicle while the hopper spreader will be in use (step bumper, trailer hitch, snowplows, etc.). Fill gas tanks.
3. Obtain the Gross Vehicle Weight Rating (GVWR), Front Gross Axle Weight Rating (FGAWR) and Rear Gross Axle Weight Rating (RGAWR) from the certification label located inside the driver-side door jamb or door.
4. With the occupants in the truck for normal hopper spreader operation, weigh the vehicle to obtain gross vehicle weight (GVW).
5. Subtract the GVW from the GVWR to determine the available material payload.
6. Obtain the weight per cubic yard (lb/cu yd) of the desired material. Divide the weight into the payload to determine the maximum volume of material that can be carried.
7. Compare the maximum volume to determine the maximum height of the material in the hopper spreader.
8. Fill the hopper with the material to the calculated height. Reweigh the vehicle with occupants and verify the GVW, Front Gross Axle Weight and Rear Gross Axle Weight are less than the vehicle's ratings.
9. Repeat Steps 7 and 8 for each type of material.

Refer to the "Determining Vehicle Payload" worksheet for an example and worksheet.

LOADING

Determining Vehicle Payload – Worksheet

Material Type	Example: Coarse Salt – Dry				
Equipment installed when vehicle was weighed	7' Poly Hopper Spreader				
Front Gross Axle Weight Rating (FGAWR) (lb)					
Rear Gross Axle Weight Rating (RGAWR) (lb)					
Gross Vehicle Weight Rating (GVWR) (lb)	8600				
Gross Vehicle Weight (empty) (lb)	– 6500				
Payload Available (lb)	= 2100				
Material Density (lb/cu yd)	÷ 1215				
Maximum Volume (cu yd)	= 1.73				
Maximum Height (approximate) (in)	24				
Loaded Front Gross Axle Weight (FGAW) (lb)					
Loaded Rear Gross Axle Weight (RGAW) (lb)					
Loaded Gross Vehicle Weight (GVW) (lb)					

MOUNTING THE SPREADER

NOTE: Periodically throughout the snow and ice control season, verify that mounting devices are secure.

⚠ CAUTION

Before lifting, verify that hopper is empty of material. The lifting device must be able to support the spreader's weight as shown in the spreader specifications table.

1. Remove the chute from the inside of the hopper:
 - a. Unlatch the rubber straps located at the rear of the lids near the handles.
 - b. Remove the screens.
 - c. Remove the screen supports.
 - d. Remove the chute and replace the screen supports and screens.
 - e. Close the lids and latch the rubber straps.
2. Remove the tailgate from the truck.
3. Attach the truck mounting bars to the sill brackets:
 - a. Measure the width between the wheel wells.
 - b. If needed, cut one or both of the supplied bars to the correct length.
 - c. Attach the bars to the sill brackets using the supplied hardware as shown.

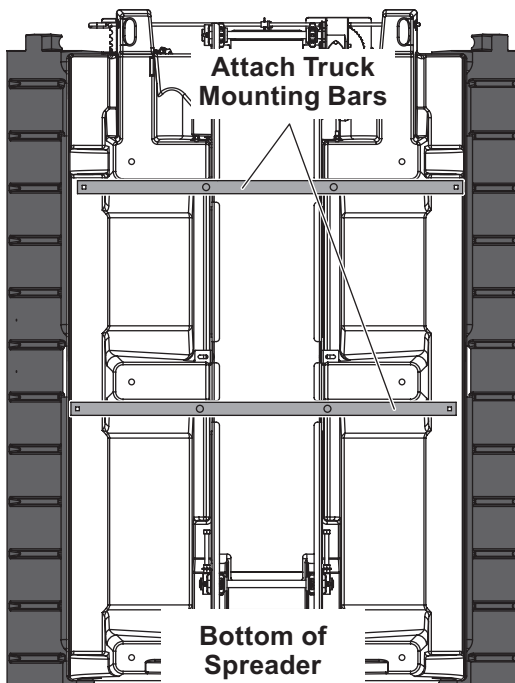

4. The spreader can be moved into the truck bed either by lifting the spreader by the four molded-in handles located on the corner legs or by sliding the spreader into the truck bed from the ground.

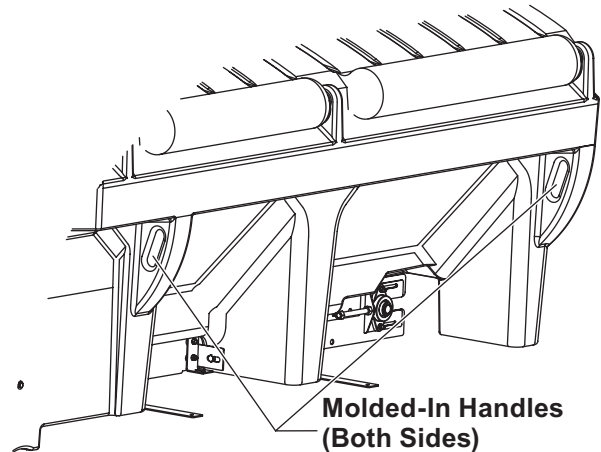

5. To lift the spreader into the truck bed from the ground, stand the spreader up on the feet at the rear of the spreader on top of two spacers at least 2" off the ground. The chute must be removed.

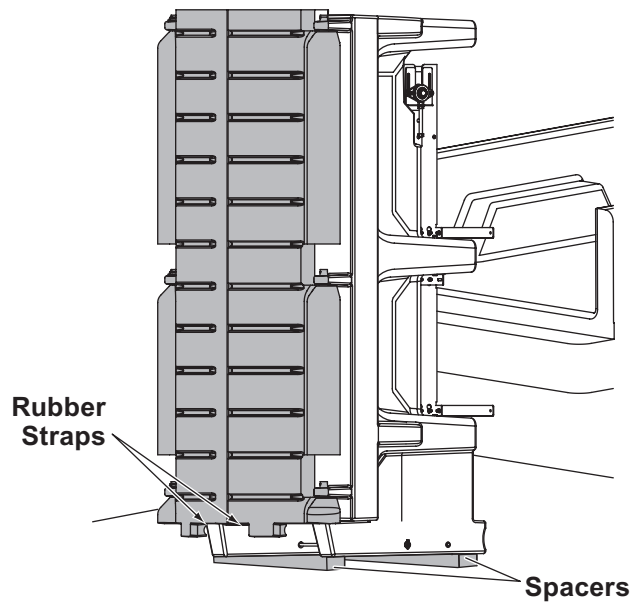

6. Position the spreader on its feet at the rear of the truck.

MOUNTING THE SPREADER

7. Tip the spreader toward the truck until the sill rests on the rear edge of the truck bed.
8. Lift the rear of the spreader and slide it into the truck bed. Two or more people are recommended for this task.
9. Center the spreader in the truck.
10. Remove the cable tie holding the wire harness to the conveyor chain. Connect the vehicle side harness to the hopper side harness.
11. To assemble the chute to the spreader:
 - a. Select the height for the chute assembly. The upper chute position (using lower two slots) is typically used for pickup truck installations..
 - b. Lift the chute onto the feed gate actuator bar and slide it down into place.
 - c. Align the holes in the hopper body with the threaded inserts in the chute, and install the pins to secure the chute to the hopper body.
 - d. Connect the spinner motor wiring harness.
12. Install the spacer between the end of the sill and the front of the truck bed as shown. If you do not have a spacer, refer to the Installation Instructions to create one. **Failure to install this spacer could result in damage to the spreader.**

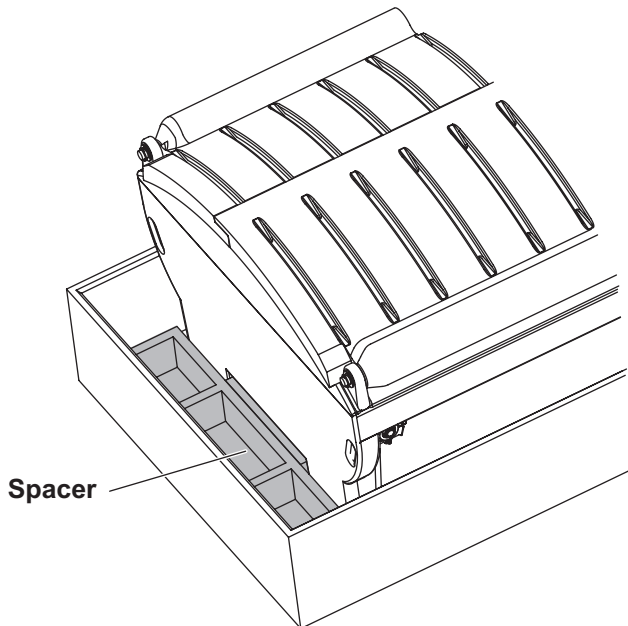

⚠ WARNING

Spreader shall be bolted to vehicle frame. Do not rely on the tie-down chains or straps alone to hold spreader in vehicle.

13. Fasten the spreader to the truck frame using the mounting bars and existing holes and hardware. If there are no holes, refer to the Installation Instructions.

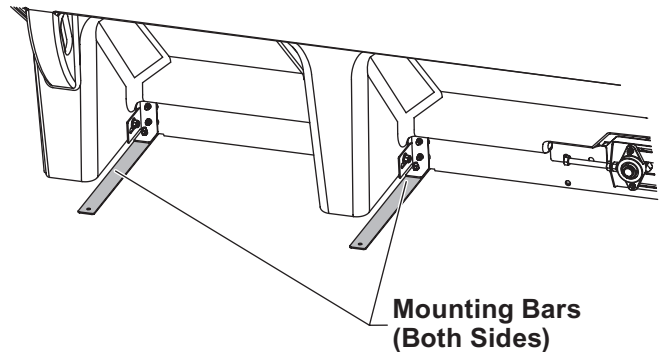

OPERATING THE SPREADER – CAB CONTROL

⚠ WARNING

Never operate equipment when under the influence of alcohol, drugs, or medications that might alter your judgment and/or reaction time.

⚠ WARNING

Never exceed 45 mph (72 km/h) when loaded spreader is attached to vehicle. Braking distances may be increased and handling characteristics may be impaired at speeds above 45 mph (72 km/h).

⚠ WARNING

Never allow children to operate or climb on equipment.

POWERING THE CONTROL

Power is not applied to the control until the vehicle ignition is turned to ACC or ON. Once the control has power it performs a light check and displays the software version on the status display. The control then checks for a connected spreader. If no spreader is detected, the control does the following:

- **nC** (no connection) appears on the red status display for five seconds;
- A single beep;
- Control enters Standby mode with no lights illuminated.

If any button is pressed on the control, it will wake and check again for spreader connection. If no spreader is detected, it will act as described above. If a spreader is detected, it will transition to Ready mode.

STARTING AND STOPPING SPREADER

⚠ WARNING

Before starting the spreader, the driver shall verify that all bystanders are a minimum of 25 feet away from operating spreader.

To start the spreader, press the ON/OFF button. The control backlights are illuminated when the vehicle ignition is ON and the spreader is connected. When the spreader is ON, the ON/OFF button and inner arc around each control knob will also illuminate.

To stop the spreader, press the ON/OFF button again.

The ON/OFF button also operates as an emergency stop when required.

NOTE: The vehicle ignition must be ON to start the spreader.

NOTE: If vehicle ignition is turned OFF while spreader is running, the motors will stop.

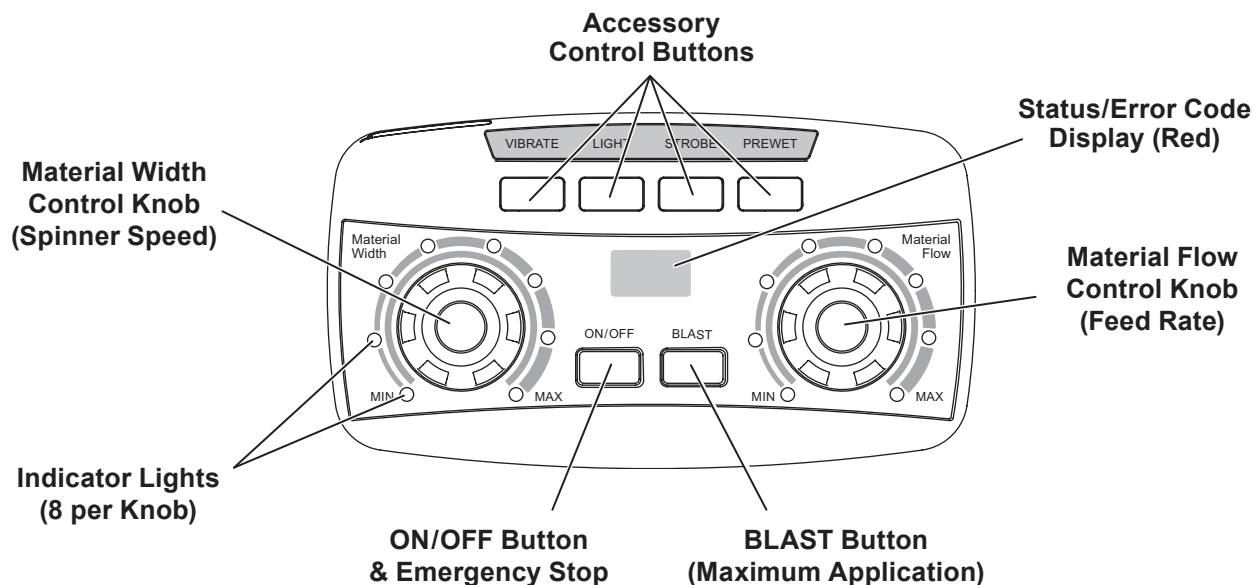

OPERATING THE SPREADER – CAB CONTROL

CONTROLLING MATERIAL APPLICATION

The material application settings can be adjusted while spreader is ON or OFF. Settings are shown by the indicator lights around the control knobs. When the spreader is OFF, a single LED will light to show the current setting. When the spreader is ON, the number of blue LEDs illuminated will increase/decrease as the knobs are turned clockwise/counterclockwise.

The hopper drive will not deliver material until the ON button is pressed.

The Material Width (left) knob controls spinner speed. Turning the knob clockwise will increase the width of the application area.

The Material Flow (right) knob controls the hopper drive. Turning the knob clockwise will increase the feed rate of material to the spinner.

Turning the control knobs counterclockwise will decrease the width of the application area and the feed rate of material.

BLAST/Maximum Application

1. Press and hold the BLAST button when maximum flow rate and application area are needed temporarily. The BLAST button will illuminate while depressed.
2. Release the button when maximum application settings are no longer needed.

NOTE: Spinner speed and material feed rate revert to the previous settings once the BLAST button is released.

CAB CONTROL MODES

Standby Mode

Vehicle ignition is set to ACC or ON; cab control is OFF. Control has power. No spreader was detected. No lights are illuminated on the control. Press any button to wake.

Ready Mode

Vehicle ignition is set to ACC or ON; cab control is OFF. Control has power. Spreader is detected.

The Material Width and Material Flow control knobs can be set to start-up conditions, but the spinner and drives will not operate until the cab control is turned ON.

Accessory lights and vibrator (if installed) are operational. The BLAST function is not operational.

ON Mode

Vehicle ignition is set to ACC or ON; cab control is ON.

Spinner and hopper motors will start. All cab control functions are operational. Accessory lights and vibrator (if installed) are operational.

During normal spreader operation, **no control codes are displayed**. Information or setup codes will appear when relevant. These codes will not stop spreader operation.

Error Mode

When an error condition occurs, spreader operation will shut down. A two-digit error code will flash on the display and a beep will sound. If there are multiple error codes, the codes will flash in a repeating sequence.

Refer to the Error Codes portion of the following Cab Control Codes table. Also see the Troubleshooting Guide section of this manual.

Once the error condition has been resolved, press the ON/OFF button to clear the error code(s). Press the ON/OFF button again to resume spreader operation.

The error code will reappear if the error condition has not been rectified. If the error condition persists, contact your authorized dealer.

Multiple resets within a short time frame will cause the hopper module to time out if components are overheating. The control will display an **EF** error code.

Accessory work lights and strobe lights can be used when an error code is in effect and will remain in their current state. The vibrator and prewet will not function.

OPERATING THE SPREADER – CAB CONTROL

CAB CONTROL CODES

Setup Codes		
Code	Definition	Procedure
Cb	Calibrate the Empty Hopper setting.	With control in ON mode, press and hold the left control knob until the Cb code displays. Calibration cycle is automatic.*
Cc	Clear calibration data for Empty Hopper setting; clear EH code.	Press the right control knob to clear all calibration data during the calibration cycle.
LS	Set LED brightness level.	With control in Ready mode, press and hold left control knob to get LS code. Release pressure and turn left control knob to desired brightness setting. Wait for confirming SL code to display.*
SL	Confirms that LED brightness level has been reset.	

* For full instructions, see the "Setup Procedures" section.

Information Codes		
Code	Definition	Response
dU	Not applicable to tailgate spreaders. Possibly indicates a harness or module issue.	Contact authorized dealer.
EH	Empty hopper (beep will sound).	Check hopper for material. Recalibrate Empty Hopper setting as described above for Cb code.
Lb	Low battery. Hopper module is sensing < 10V. (Lb becomes an error code when module senses < 6V.)	Refer to the Lb row under "Error Codes" (next table).

Error Codes – Spreader Operation Stopped			
Code	Definition	Possible Cause	Suggested Solution
bb	Bad button	Button is stuck. Button was pressed while vehicle ignition was entering ACC or START mode.	Inspect control. Free up button. Do not press any spreader cab control buttons while the vehicle ignition is being engaged.
bH	Bad hopper	Possible module or control mismatch.	Replace control or module. Use only genuine service parts. Contact authorized dealer.
CE	No communication with spreader module	Loose connection. Module lost power.	Confirm that spreader and control harnesses are connected to the vehicle harness. Check power to spreader module, all connections, fuses and power studs. Check that B port is plugged in.
CP	Chute present fault	Chute is open. Bad connection at chute position mag switch. (Can occur when driving on rough surface.)	Close the chute. Reset the control by pressing the ON/OFF button. If CP code continues to display, contact authorized dealer.
Ct	Control is hot.	Cab temperature is too high. Control overheated.	Turn off spreader and allow control to cool off.

Table continues on next page.

OPERATING THE SPREADER – CAB CONTROL

CAB CONTROL CODES *continued*

Error Codes – Spreader Operation Stopped			
Code	Definition	Possible Cause	Suggested Solution
Ct	Control is hot.	Cab temperature is too high. Control overheated.	Turn off spreader and allow control to cool off.
EF	Excessive drive faults	Too many HO and/or SO error codes; hopper module overheating.	Control times out for 60 seconds. Ensure that conveyor and/or spinner are not jammed.
HO	Hopper overload – software trip	Drive system has high current. Material is jammed.	Inspect conveyor; clear material jam or fix chain as needed.
HO.	Hopper overload – hardware trip	Chain is damaged.	
HP	Hopper power issue. No motor present.	Hopper drive motor is not connected. Possible motor defect.	Check connections to the conveyor drive motor (P—FEED and GND posts on the module and studs on the motor). Replace the motor.
Lb	Low battery. Hopper module is sensing $\leq 6V$.	Bad connection or low battery. Snowplow or other vehicle power use may be driving down voltage.	Voltage is measured at the hopper module, so Lb code may indicate cable voltage loss. Check battery, alternator and connections.
nC	No connection.	Spreader not connected to vehicle harness.	Connect vehicle and spreader harness. Check vehicle harness fuse. Inspect spreader and vehicle harnesses. Check module.
OH	Overheating	Spreader module is too hot.	Allow a cool-off period of 60 seconds or longer. Check for loose harness connections. Check accessory connections. Check integrity of accessory wiring and harness. Clear jammed material. Contact authorized dealer.
OH.	Overheating module – microprocessor	Spreader module malfunction. Accessories wiring/function problem. Drive motor overload.	
rS	Reset of spreader module	Power loss to module detected on startup.	Reset the control by pressing the ON/OFF button. Check vehicle harness and battery connection.
SO	Spinner drive overload – software trip	Material jammed in chute. Spinner shaft is damaged.	Inspect spinner and spinner drive components for alignment and condition. Check for damage to bearings, belts, shafts and sprockets. Adjust and replace parts as required.
SO.	Spinner drive overload – hardware trip	Drive belt is misaligned.	
SP	Spinner power issue. No motor present.	Spinner drive motor is not connected. Possible motor defect.	Check connections to the motor (SPIN and GND posts on the module). Replace the motor.

OPERATING THE SPREADER – CAB CONTROL

SETUP PROCEDURES

Calibrate the Empty Hopper Setting (*Cb* and *EH* Codes)

Calibrating the empty hopper setting enables the cab control to alert the operator when the hopper is empty.

Recalibrate the empty hopper setting at the start of each ice-control season.

1. Ensure that the hopper is empty before beginning the calibration.
2. Turn the vehicle ignition to ACC or ON. Press the ON/OFF button on the cab control to turn the control ON.
3. Press and hold the Material Width (left) knob for approximately 10 seconds until the **Cb** code displays.
4. The calibration cycle will begin. The blue LEDs around the Material Flow (right) knob will illuminate in succession until all 8 are lit.
5. When the automatic calibration cycle is complete, the control will automatically revert to the previous material application settings.

If the control is turned OFF or loses power during the calibration cycle, the calibration data will be lost. Make sure the control is ON and restart the calibration process at Step 3.

Once the empty hopper setting has been calibrated, the **EH** code will flash on the display and a beep will sound whenever the hopper is empty. The **EH** code is informational only and will not stop spreader operation.

Clearing Empty Hopper Calibration Data (*Cc* Code)

The empty hopper calibration may be cleared, if desired. The control will no longer display the **EH** status code when the hopper is empty.

Start the calibration cycle as described above. At Step 4, press the Material Flow (right) knob during the calibration cycle to clear *all* calibration data. The **Cc** (Clear Calibration) code will display and the control will exit **Cc** mode automatically.

Adjust LED Brightness Level (*LS* and *SL* Codes)

The brightness setting of the cab control lights can be adjusted from 1 to 16. The factory default setting is 8.

1. Turn the vehicle ignition to ACC or ON. If necessary, press the cab control ON/OFF button to turn the control OFF.
2. Press and hold the Material Width (left) knob for approximately 3 seconds until the **LS** code is displayed.
3. Release the knob and turn it clockwise or counterclockwise to increase/decrease the brightness level. The light level number will show in the status display.
4. After selecting the desired brightness level, wait a few seconds for the **SL** confirmation code to display.

NOTE: A brightness level setting of 12 or higher is recommended for daylight conditions.

OPERATING THE SPREADER

DUMP FUNCTION

The dump function allows the operator to activate the conveyor to empty the hopper after use or load material into a walk-behind spreader.

The dump function is a two-handed operation requiring the operator to press two buttons at the same time. The conveyor buttons are located on two sides of the power box/hub on the driver's side of the hopper.

1. Disconnect the chute and remove it entirely. Position the material receptacle or walk-behind spreader under the end of the conveyor.
2. Standing to one side of the conveyor exit, press and hold both buttons to operate the conveyor.
3. To stop the conveyor, release one or both buttons.

ACCESSORY WORK LIGHT

Electric-powered spreaders are equipped with a button to operate an accessory work light. The button is on the rear of the power box on the driver's side of the hopper. The work light can also be turned on and off from the cab control.

The accessory rear lighting package includes a harness, relay, fuse and LED work light. A second LED light and harness can be added as well. Accessory work light kits are available through your authorized dealer.

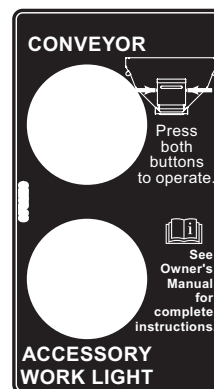
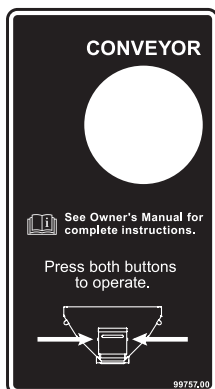
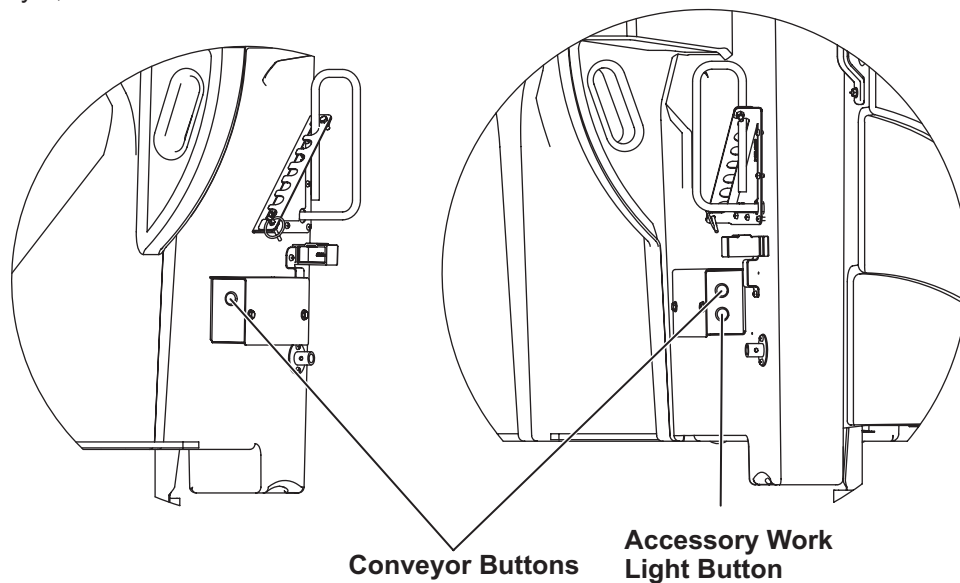

REMOVING THE SPREADER

⚠ CAUTION

Before lifting, verify that hopper is empty of material. The lifting device must be able to support the spreader's weight as shown in the spreader specifications table.

1. The spreader can be removed from the truck bed either by lifting the spreader by the four molded-in handles located on the corner legs or by sliding the spreader out of the truck bed onto the ground.
2. First make sure all material has been removed from the spreader and the chute is detached. To empty the spreader and remove the chute:
 - a. Remove the two pins that hold the chute to the hopper body.

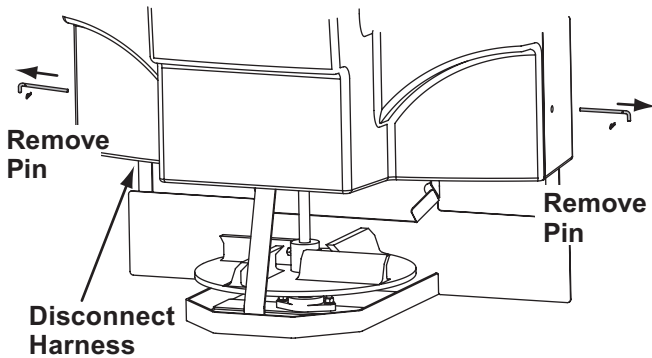

- b. Disconnect the spinner motor connector.
 - c. Grasp the chute, raise it and remove it from the hopper body.
 - d. Operate the hopper to convey all material from the spreader.
 - e. Remove the sill deflectors by loosening the bolts for the bearing and gearbox. Slide out the deflectors and tighten bolts.
3. Disconnect the electrical connections at the spreader.
 4. Remove any means used to attach the spreader to the truck bed and ensure the lids are closed securely.

5. To remove the spreader without a lifting device, two or more people are recommended. Move spreader rearward until it balances at the rear of the bed. Carefully lower the back of the spreader to the ground so it is resting on its feet.
6. Tip the spreader up onto spacers at least 2" tall, so it is fully supported by the feet.

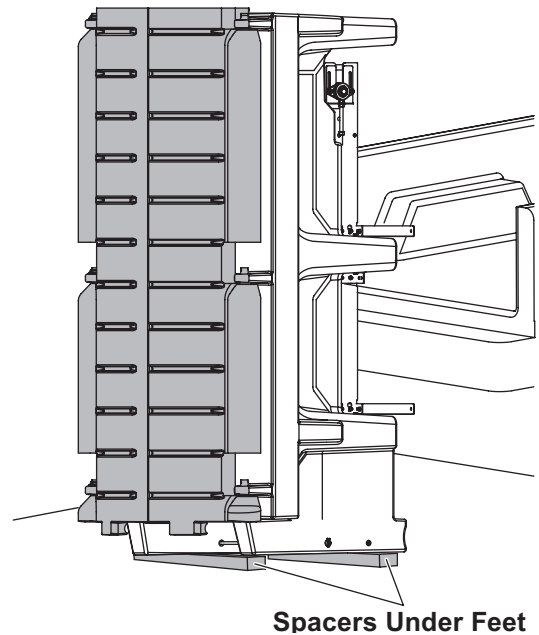

7. **Do not leave an unsecured spreader standing on its feet.** After pulling the truck away, either lower the spreader so it is resting on its six legs or properly support it with blocks and secure it as directed under the Storage in the maintenance section of this manual. If lowering the spreader onto its 6 legs, place spacers under the legs so the feet at the rear of the spreader are off the ground.

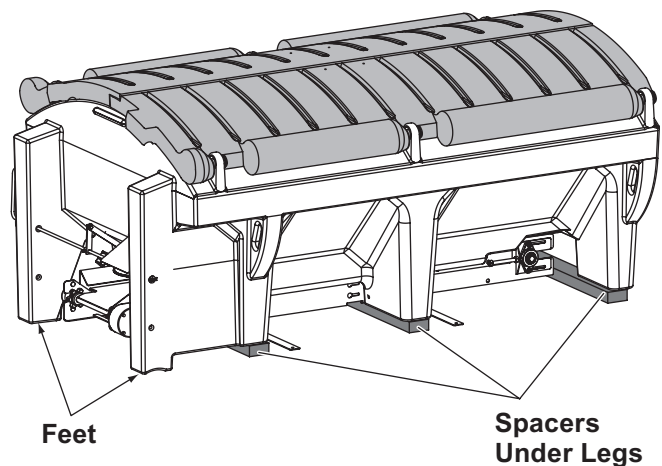

MAINTENANCE

⚠ CAUTION

Disconnect electric power at spreader electrical wiring harness connection and tag out if required before servicing or performing maintenance.

GREASE FITTINGS

To keep your spreader running smoothly, lubricate grease fittings after each use and at the end of each season.

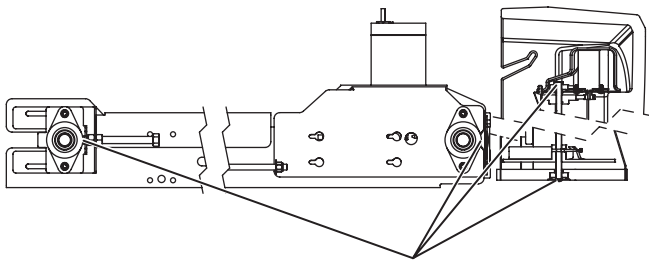

Grease after each use with a good quality multipurpose grease.

CONVEYOR PINTLE CHAIN TENSION

1. Periodically check the conveyor chain tension. The spreader should be out of the vehicle. To check the tension, measure in 20"–24" from the rear edge of the sills. Push up on the chain with your hand. The conveyor chain should lift up 1"–3" off the conveyor chain guide.
2. If the slack is greater than 3", loosen the two bearing mounting bolts on each side of the conveyor idle roller on cab end of hopper.
3. Loosen the jam nut on one of the take-up bolts, then tighten (clockwise) the take-up bolt one full revolution. Repeat evenly on the other side.

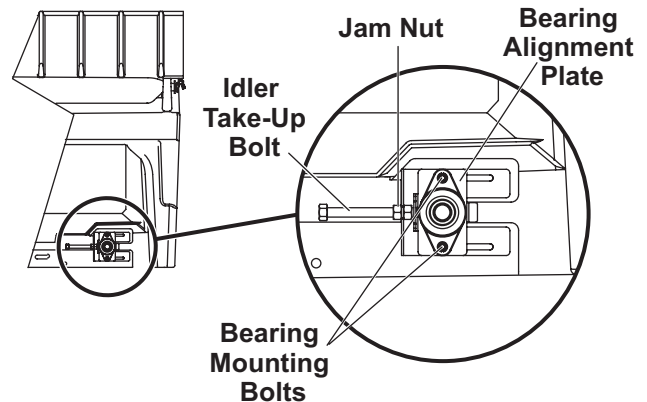

AFTER EACH USE

⚠ CAUTION

DO NOT leave unused material in hopper. Material can freeze or solidify, causing unit to not work properly. Empty and clean after each use.

- Wash out the hopper and rinse off all external surfaces.
- Clean out any trapped/frozen material from between the pintle chain and the vehicle bed surface.
- Apply dielectric grease on all electrical connections to prevent corrosion at the beginning and end of the season and after each use.
- Lubricate all grease fittings with good quality multipurpose grease.

MAINTENANCE

STORAGE

The spreader can be stored on end (on its feet) for storage; however, steps must be taken to properly support it with blocks and secure it.

⚠ CAUTION

Before lifting, verify that the hopper is empty of material. The lifting device must be able to support the spreader's weight as shown in the spreader specifications table.

1. Back the truck near a wall, fence or other permanent structure so that there is enough room to remove the spreader but the spreader will be against the structure when it is taken out of the truck.
2. Remove the spreader from the truck following the instructions in the Removing the Spreader section of this manual.
3. Add blocks supporting the sides of the hopper body and conveyor, as shown.

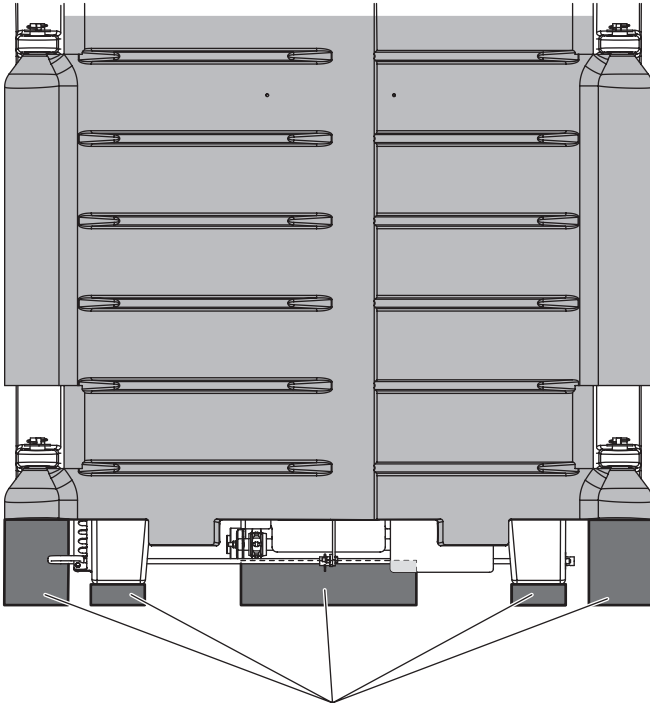

Support sides and conveyor with blocks.

4. Secure the spreader to the structure using chains or straps to ensure that it cannot tip or fall.

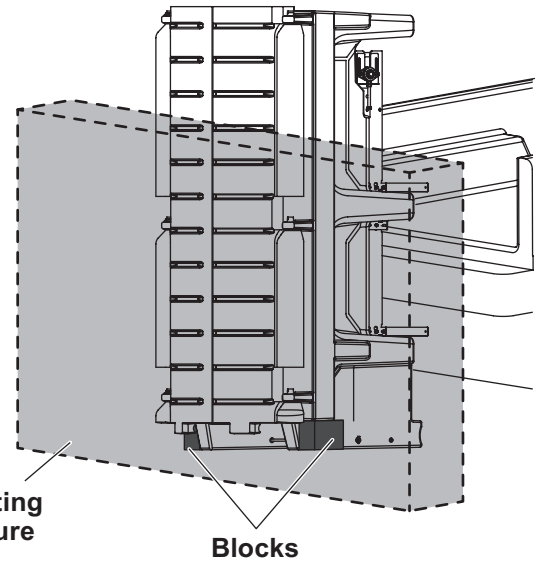

At the End of Each Season or After Extended Storage

- Wash out the hopper and rinse off all external surfaces.
- Apply dielectric grease on all electrical connections to prevent corrosion.
- Lubricate all grease fittings with good quality multipurpose grease.
- Oil or paint all bare metal surfaces.

RECYCLE

When your spreader has performed its useful life, many of its components can be recycled as steel. Gear oil shall be disposed of according to local regulations. Balance of parts made of plastic shall be disposed of in customary manner.

ELECTRICAL COMPONENTS

VEHICLE HARNESS DIAGRAM

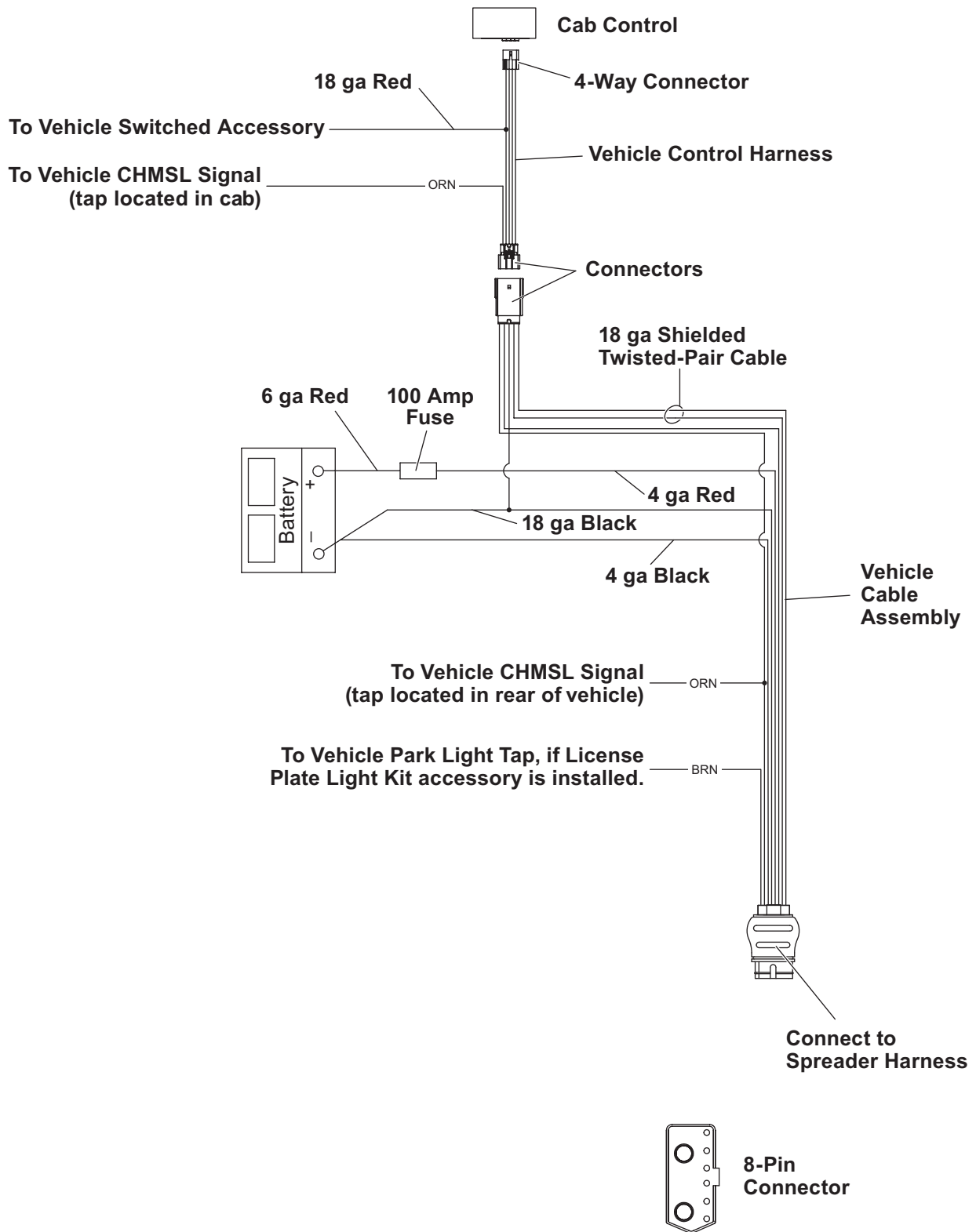

ELECTRICAL COMPONENTS

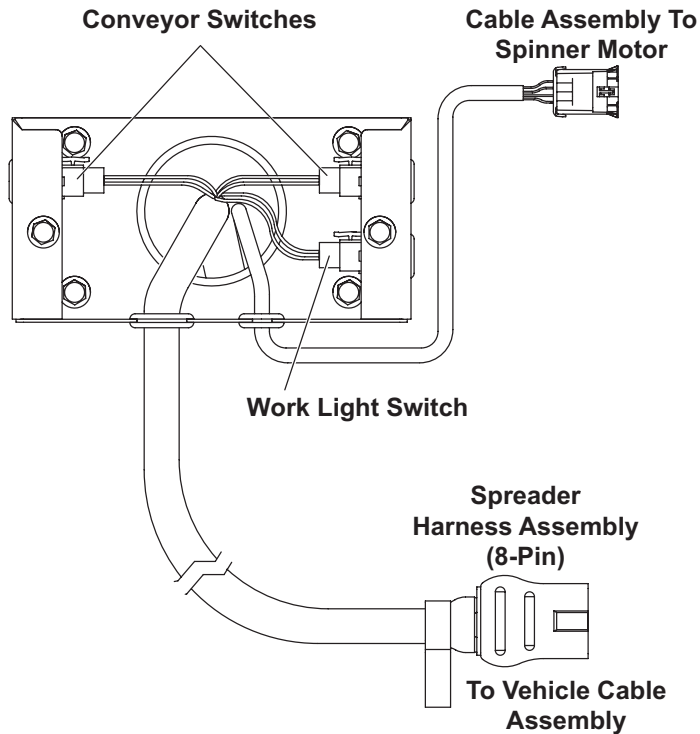
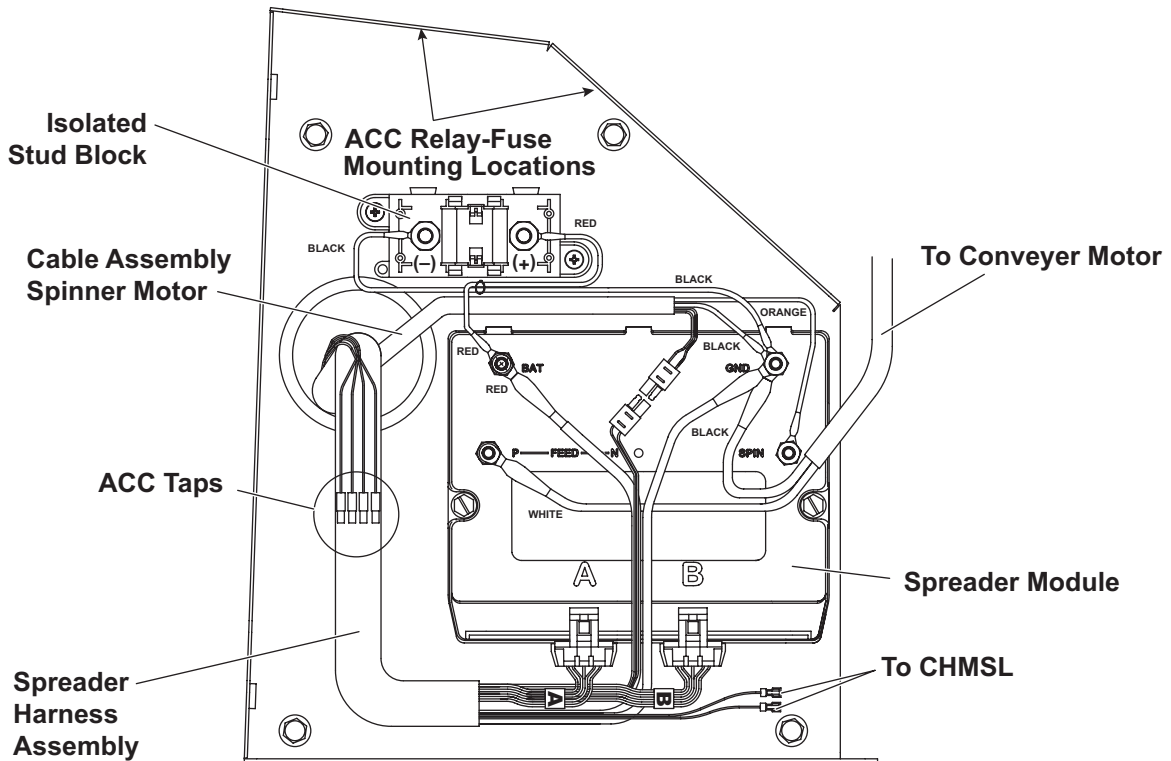

TROUBLESHOOTING GUIDE

Please see your distributor for service. The troubleshooting reference table below may guide you in diagnosing the issue.

For a reference table of the cab control error codes, see the "Operating the Spreader – Cab Control" section of this manual.

Before servicing the spreader:

- Review all safety information.
- Confirm that all electrical connections are tight and clean.
- Confirm that nothing is jammed in the hopper.

Problem	Possible Cause	Suggested Solution
No power to cab control. Ignition and control switches ON; control knob indicator lights not illuminated.	1. Control is in Standby mode. Spreader is not connected.	1. Press any button on control to wake.
	2. Control connector plug is loose.	2. Check plug connection at cab control.
	3. Switched accessory connection is poor or faulty battery.	3a. Check for low battery. 3b. Check switched accessory connection.
	4. Blown fuse.	4. Replace spreader vehicle battery cable fuse.
	5. Vehicle control harness is damaged.	5. Repair or replace damaged wires or harness as required.
Turning control knobs does not change motor speed.	1. Malfunctioning cab control.	1. Replace cab control.
	2. Malfunctioning spreader module.	2. Replace spreader module.
Spreader does not operate.	1. Overloaded condition is causing over-current protection to activate.	1. Reset cab control by pressing the ON/OFF switch.
	2. Wire harness is damaged or has an open circuit between cab control and spreader.	2a. Check plug connections at cab control and spreader. 2b. Check wire connections at spreader motor and at vehicle battery: disconnect motor leads, turn Material Width and Material Flow knobs to maximum, and check for voltage at motor leads. 2c. Repair or replace damaged wires and connectors. 2d. Check the 100 A in-line fuse on the 22" red cable. Replace if necessary.

TROUBLESHOOTING GUIDE

Problem	Possible Cause	Suggested Solution
Spinner does not turn. Motor is running.	Unplug the spreader harness and tag out, if required, before performing any of the following repairs.	
	1. Obstruction is preventing rotation.	1. Clear obstruction.
	2. Drive belt is loose or damaged.	2. Adjust the tension or replace the belt if worn or damaged.
	3. Motor pulley not secured to motor shaft.	3. Tighten the pulley set screw or replace the pulley if damaged.
	4. Spinner pulley is not secured to spinner shaft.	4. Tighten the pulley set screw or replace the pulley if damaged.
	5. Spinner shaft bearings are dry or seized.	5. Grease or replace bearings.
Conveyor chain not moving. Spinner is turning.	Unplug the spreader harness and tag out, if required, before performing any of the following repairs.	
	1. Obstruction is preventing rotation.	1. Clear obstruction.
	2. Gearbox is damaged.	2. Replace gearbox if output shaft does not turn when motor shaft turns.
	3. Conveyor sprockets are not secured to shafts.	3. Replace or tighten set screws. Replace shafts or sprockets if damaged.
	4. Conveyor pintle chain is loose or damaged.	4. Adjust pintle chain tension. Replace pintle chain if damaged.
	5. Conveyor pintle chain is not aligned.	5. Align pintle chain to ride centered on rollers.
	6. Conveyor pintle chain shaft bearings are seized or otherwise damaged.	6. Grease or replace bearings.
Material in hopper does not flow. Conveyor pintle chain and spinner are moving.	Unplug the spreader harness and tag out, if required, before performing any of the following repairs.	
	1. Feed gate is closed.	1. Open feed gate fully, and then adjust to desired opening size.
	2. Obstruction in hopper.	2. Clear obstruction.
	3. Material bridged.	3. Clear the bridged material.



Fisher Engineering
50 Gordon Drive
Rockland, ME 04841-2139
www.fisherplows.com

 A DIVISION OF FISHER, LLC

Copyright © 2016 Douglas Dynamics, LLC. All rights reserved. This material may not be reproduced or copied, in whole or in part, in any printed, mechanical, electronic, film or other distribution and storage media, without the written consent of Fisher Engineering. Authorization to photocopy items for internal or personal use by Fisher Engineering outlets or spreader owner is granted.

Fisher Engineering reserves the right under its product improvement policy to change construction or design details and furnish equipment when so altered without reference to illustrations or specifications used. Fisher Engineering or the vehicle manufacturer may require or recommend optional equipment for spreaders. Do not exceed vehicle ratings with a spreader. This product is manufactured under the following U.S. patents: 7,400,058; 7,737,576. Fisher Engineering offers a limited warranty for all spreaders and accessories. See separately printed page for this important information. The following are registered (®) or unregistered (™) trademarks of Douglas Dynamics, LLC: FISHER®, POLY-CASTER™.

Printed in U.S.A.