

Installation Guide

This Manual Must Be Read Before Operating The Equipment

SNOWEX[®]

LEADERS IN ICE CONTROL

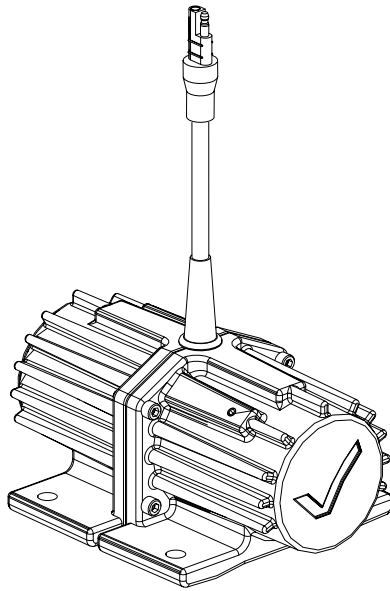

VBR-400

TRYNEX[®]
INTERNATIONAL

CUSTOMER COPY

Madison Heights, Michigan 48071
800-725-8377
www.snowexproducts.com

© TrynEx International 2013
(REV A) F50853

Introduction

This VBR-400 is designed to increase material flow on the SnowEx Super-Maxx 9800X when spreading low-flow materials such as moist salt and sand-salt mix. This kit connects directly to the existing Control Module of the Spreader, integrating completely with the existing controls – there is no need for additional switches.

Please read this Installation Guide carefully before installing. Pay particular attention to safety messages.

Refer to the Owner's Manual of your Spreader for Operation, Maintenance and Troubleshooting information.

CONTENTS

Installation Instructions	
Installing the Vibrator	3 - 4
Wiring Installation	5 - 7
Parts Key	8

WARNING

Remember, most accidents are preventable and caused by human error. Exercising of care and precautions must be observed to prevent the possibility of injury to operator or others!

Before working with the spreader, secure all loose fitting clothing and unrestrained hair.

Always wear safety glasses with side shields when servicing spreader. Failure to do this could result in serious injury to the eyes.

Never weld or grind on equipment without having a fire extinguisher available.

Park vehicle on level ground before servicing the spreader.

Follow all vehicle safety information.

Have a question or need assistance?

SnowEx Customer Care

1-800-SALTERS

or (248) 586-3500

Monday through Friday 8:00 AM to 4:30 PM EST

Fax: (248) 691-8378

E-mail: customercare@trynexfactory.com

Website: www.snowexproducts.com



Tools List

3/4" Wrench	9/16" Socket w/ Ratchet x2	3/8" Socket w/ Ratchet
Grinder	Step Drill Bit [for 1-1/8 Hole]	Ratchet Extension
Spray Primer and Paint (optional)	5/16" Nut Runner	Eye Protection
Drill	Flat Screwdriver (for prying)	Dielectric Grease
3/8" Drill Bit	1/2 Socket w/ Ratchet	Tongue-and-Groove Pliers (Channellocks).
9/16" Wrench	7/16" Socket w/ Ratchet	

Installation Instructions

Model # VBR-400

Installing the Vibrator

STEP 1

Remove the Nut from the Inverted-V on the Front, Passenger-Side Corner.

STEP 2

Inside the Hopper...

Grind the welds off the Weld-Stud. Once the welds are ground off, the Weld-Stud can be removed from the Inverted-V.



WEAR EYE PROTECTION.

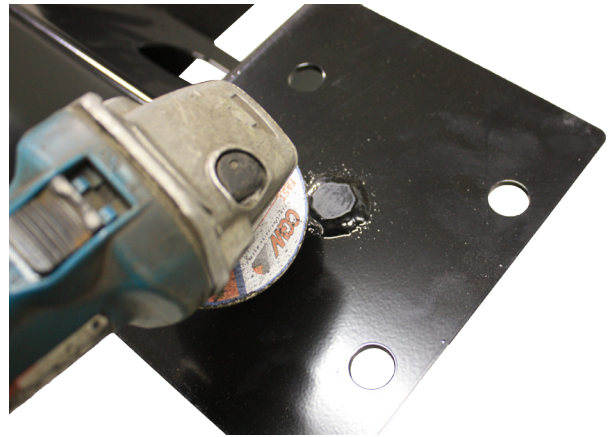

STEP 3

If desired, prime and re-paint where the powder-coat has been removed by the grinder.

STEP 4

Set the Vibrator on top of the Inverted-V to use as a template for drilling the mouting holes in the hopper. Drill the four mounting holes with a 3/8" bit.



Installation Instructions

Model # VBR-400

STEP 5

Mount the Vibrator to the outside of the hopper. Use the hardware provided.



NOTE

Install so the Vibrator are positioned in relation to each other as shown. Pay attention to the heads of the black bolts.



VIBRATOR INSTALLATION IS FINISHED.

Installation Instructions

Model # VBR-400

Installing the Wiring

STEP 1

Remove the Auger Extension Cover.

STEP 2

Remove the Clear Cover from the Control Module Box.

STEP 3

Remove all wires from the 'GND -', 'AUGER +' and 'AUGER -' Studs.

STEP 4

Drill a 1-1/8" Hole in the Control Box in the location shown.

Drill the hole here.

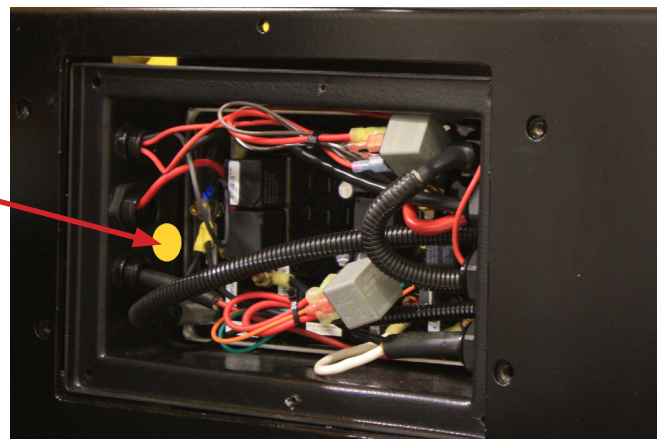

STEP 5

Insert the VBR-400 Harness [F50846] through the hole drilled in Step 2. Thread on 1/2" NPT Nut [D6781] and tighten.

STEP 6

Reconnect the Auger Harness to the 'AUGER +' and 'AUGER -'.

STEP 7

Connect the Black Wire (-) of the VBR-400 Harness to the 'GND -' Stud. Re-connect the wires that were removed in Step 3. Tighten the Nut (and washer) onto the Stud.

STEP 8

Connect the Red Wire (+) of the VBR-400 Harness to the 'VIBRATE' Stud.

STEP 9

Refer to the Diagram on the next page to check that all wiring is connected correctly.

STEP 10

Route the VBR-400 Harness along the frame and to the Vibrator. Use zip-ties (included in kit) to secure.

Installation Instructions

Model # VBR-400

STEP 11

Connect the Vibrator. Use Dielectric Grease.

STEP 12

Test the Vibrator using the Controller.

STEP 13

Re-Install the Clear Cover on the Control Module Box.

STEP 14

Re-Install the Auger Extension Cover.

WIRING INSTALLATION IS FINISHED.

Control Diagram

Model # VBR-400

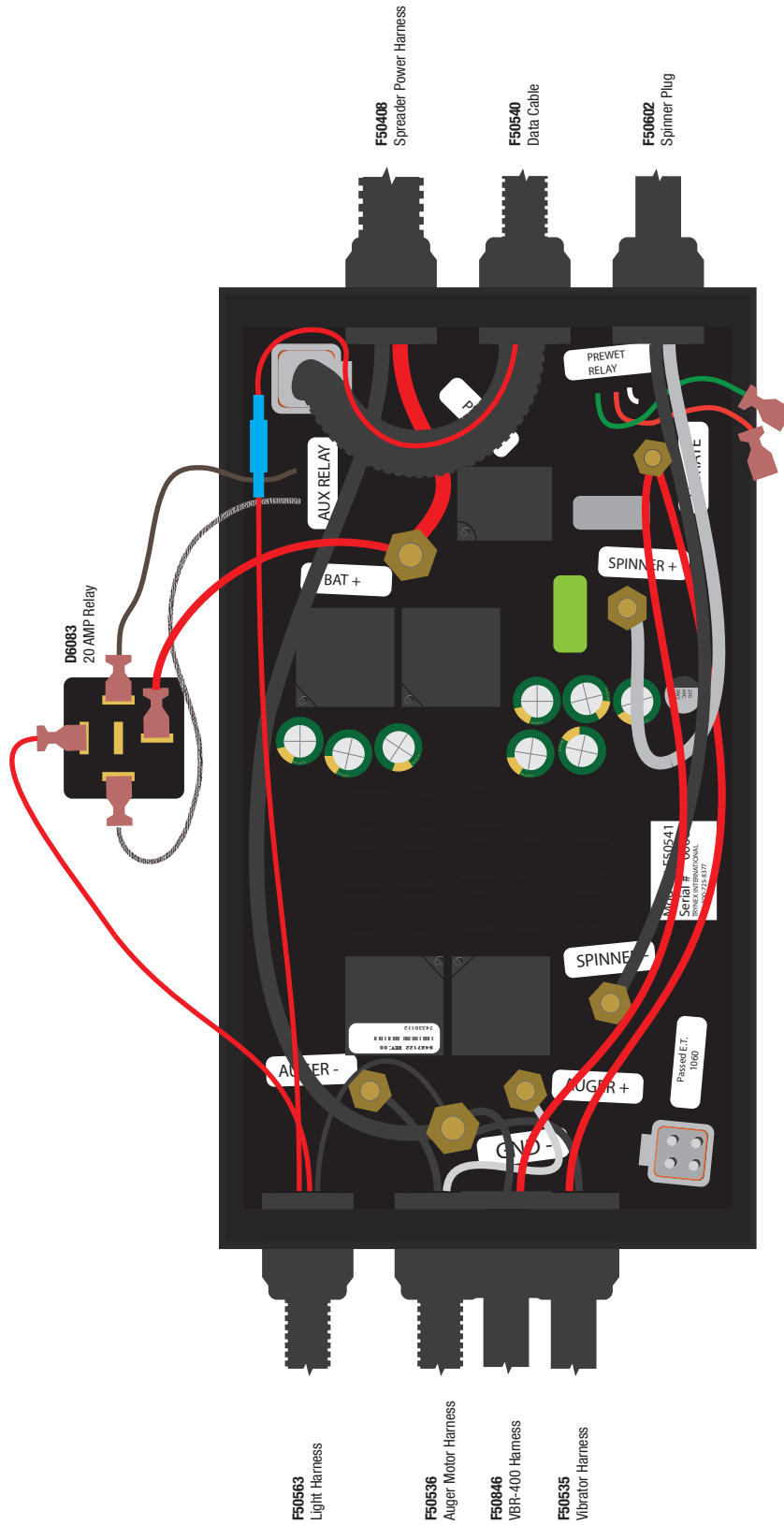

Notes

Notes



A series of horizontal lines for writing, starting from the first line below the header and continuing down the page.

